

IDEAL-PAK®

PERFORMANCE Line

PRODUCT DATA SHEET
MODEL: ME2-CEM
 TOP FILL CONFIGURATION

Industry Solutions Since 1949

SEMI-AUTOMATIC NET WEIGHT LIQUID FILLING MACHINES - ME SERIES





NET WEIGHT FILLING & CLOSING FOR 1 THROUGH 5 GALLON METAL OR PLASTIC CONTAINERS



CONTAINER SIZE

Small Containers	
1/2 Pint	• Pails
Pints	Kegs
• Quarts	Drums
• Gallons	Totes

INDUSTRIES SERVED

Paints & Coatings	
Chemicals	
Lubricants	
Food & Beverage	

ABOUT IDEAL-PAK

Ideal-Pak Liquid Filling Machines are designed to increase your yields, productivity and efficiency. Choose from Automatic to Semi-Automatic or Manual Configurations to fill small containers up to drums and totes. Ideal-Pak customers are in the paint and coatings, lubricants, chemicals and food & beverage industries.

Ideal-Pak is also your first source for a wide variety of closing machines, lid placers and precision nozzles, plus parts and service, (including Neupak).

May be covered by one or more of the following U.S. Patents: #5,505,233, #5,823,406, #6,148,877, #6,595,250

PRODUCT OVERVIEW

The Ideal-Pak PERFORMANCE Line is the economical Semi-Automatic Filling solution. Electronic net weight filling, pneumatic controls, Rice Lake touch pad weight control, single or double filling positions and a variety of closing options handle a wide variety of applications and container sizes.

FEATURES

- Fill by Weight (Electronic Net Weight Filling).
- Dual Ideal-Pak Cone Nozzles configured for top filling.*
- Quarts, 1-6 Gallon Metal or Plastic Containers.
- 5 Gallon Roller closer (optional).
- Rice Lake Weight Controller with Touch Pad Controls.
- Table-Top Chain Conveyor.
- Heavy-duty Casters with locks for portability.
- Compact machine footprint.
- Rigid Steel Frame Construction.

*Bottom Fill and Inside Fill Available



Ideal-Pak Incorporated | 4607 Dovetail Drive | Madison, WI 53704
 Phone: 608-241-1118 | Toll Free: 800-383-1128 | Fax: 608-241-4448 | www.ideal-pak.com

Semi-Automatic Net Weight Liquid Filling Machine

MACHINE SPECIFICATIONS	
Electrical	120 VAC, 1Ø, 60HZ
Air (per head)	10 CFM @ 80 - 90 PSI (Clean Dry Air)
Speed*	2 Head
Quart	8 - 12 CPM
Gallon	6 - 10 CPM
5 Gallon	3 - 6 CPM
6 Gallon	2 - 5 CPM
Accuracy: To Within \pm .10 lbs	
*Fill rates will vary depending on container size, container shape, fill opening, accuracy required, product supply, as well as individual product characteristics and operation mode.	

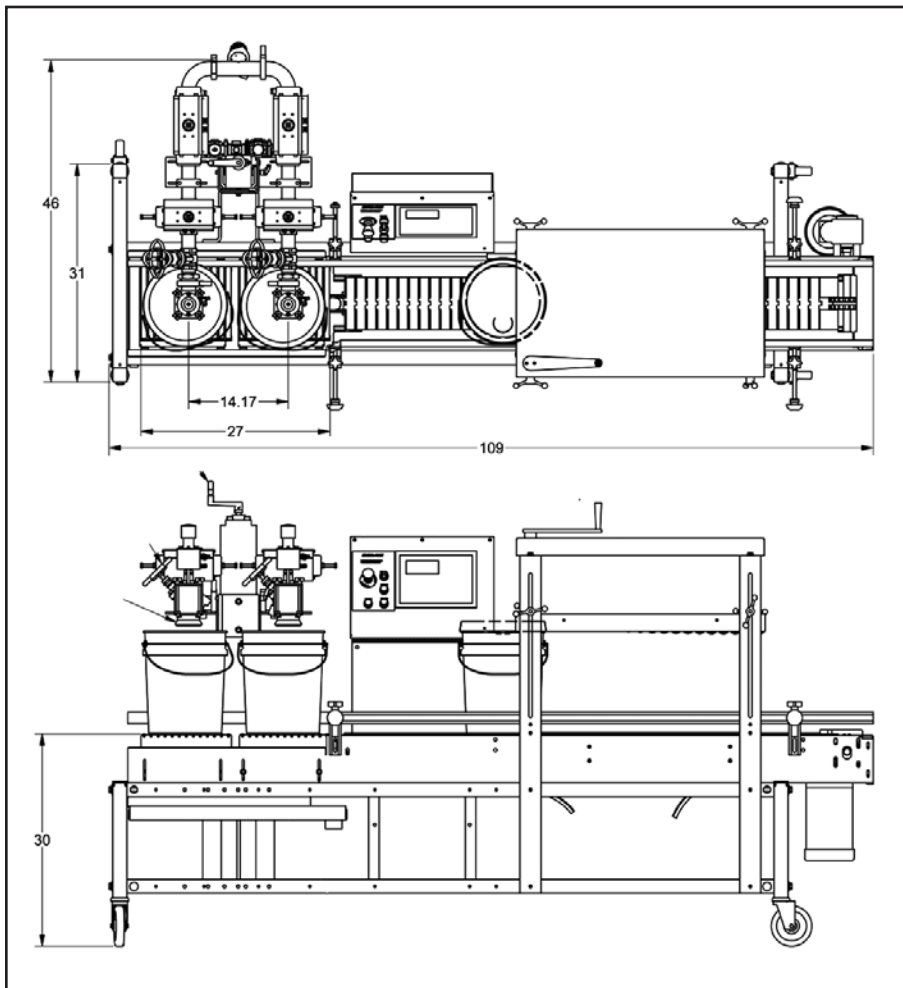

OPTIONS

- Additional Fill Carts (up to 2 heads)
- Additional Product Contact Parts
- Air Diaphragm Pump Control
- DFS™ Upgrade (Limited Nozzles)
- Extended Plug & Bottom Up Filling
- Flush Trough for Remote Cleaning
- Gravity Roller Conveyors
- Hand Capper
- Lagable Level Pads
- Nitrogen Purge Controls
- Friction Lid Press Plate
- Product Contact Parts Mounted on Fill Cart
- Purgeable Instrument Bezel
- Recommended Spare Parts Package
- Remote air operated Flush Control Box for Filling Module
- Sanitary Product Contact Parts
- Type X NFPA 496 Control Module

Subject to changes and modifications without notice.

May be covered by one or more of the following U.S. Patents: #5,505,233, #5,823,406, #6,148,877, #6,595,250

ME2-CEM 5-2015

